

LH2111/LH2311 Dual Voltage Comparators

General Description

The LH2111 series of dual voltage comparators are two LM111 type comparators in a single hermetic package. Featuring all the same performance characteristics of the single, these duals offer in addition closer thermal tracking, lower weight, reduced insertion cost and smaller size than two singles. For additional information see the LM111 data sheet and National's Linear Application Handbook.

The LH2111 is specified for operation over the -55°C to $+125^{\circ}\text{C}$ military temperature range. The LH2311 is specified for operation over the 0°C to 70°C temperature range.

Features

- Wide operating supply range
- Low input currents
- High sensitivity
- Wide differential input range
- High output drive

$\pm 15\text{V}$ to a
single $+5\text{V}$
6 nA
10 μV
 $\pm 30\text{V}$
50 mA, 50V

Connection Diagram

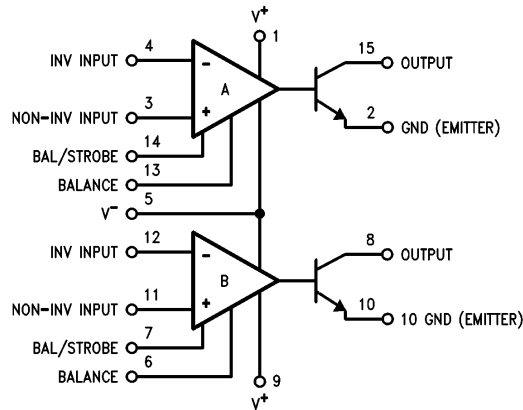

Order Number LH2111D, LH2111D/883 or LH2311D
See NS Package Number D16C

TL/K/10116-1

Absolute Maximum Ratings

If Military/Aerospace specified devices are required, please contact the National Semiconductor Sales Office/Distributors for availability and specifications.

Total Supply Voltage ($V^+ - V^-$)	36V
Output to Negative Supply Voltage ($V_{OUT} - V^-$)	50V
Ground to Negative Supply Voltage ($GND - V^-$)	30V
Differential Input Voltage	$\pm 30V$

Input Voltage (Note 1)	$\pm 15V$
Power Dissipation (Note 2)	500 mW
Output Short Circuit Duration	10 sec
Operating Temperature Range LH2111	-55°C to $+125^\circ\text{C}$
LH2311	0°C to $+70^\circ\text{C}$
Storage Temperature Range	-65°C to $+150^\circ\text{C}$
Lead Temperature (Soldering, 10 sec)	300°C

Electrical Characteristics Each Side (Note 3)

Parameter	Conditions	Limits		Units
		LH2111	LH2311	
Input Offset Voltage (Note 4)	$T_A = 25^\circ\text{C}, R_S \leq 50k$	3.0	7.5	mV Max
Input Offset Current (Note 4)	$T_A = 25^\circ\text{C}$	10	50	nA Max
Input Bias Current	$T_A = 25^\circ\text{C}$	100	250	nA Max
Voltage Gain	$T_A = 25^\circ\text{C}$	200	200	V/mV Typ
Response Time (Note 5)	$T_A = 25^\circ\text{C}$	200	200	ns Typ
Saturation Voltage	$V_{IN} \leq -5\text{ mV}, I_{OUT} = 50\text{ mA}$ $T_A = 25^\circ\text{C}$	1.5	1.5	V Max
Strobe On Current	$T_A = 25^\circ\text{C}$	3.0	3.0	mA Typ
Output Leakage Current	$V_{IN} \geq 5\text{ mV}, V_{OUT} = 35V$ $T_A = 25^\circ\text{C}$	10	50	nA Max
Input Offset Voltage (Note 4)	$R_S \leq 50k$	4.0	10	mV Max
Input Offset Current (Note 4)		20	70	nA Max
Input Bias Current		150	300	nA Max
Input Voltage Range		± 14	± 14	V Typ
Saturation Voltage	$V^+ \geq 4.5V, V^- = 0$ $V_{IN} \leq -5\text{ mV}, I_{SINK} \leq 8\text{ mA}$	0.4	0.4	V Max
Positive Supply Current	$T_A = 25^\circ\text{C}$	6.0	7.5	mA Max
Negative Supply Current	$T_A = 25^\circ\text{C}$	5.0	5.0	mA Max

Note 1: This rating applies for $\pm 15V$ supplies. The positive input voltage limit is 30V above the negative supply. The negative input voltage limit is equal to the negative supply voltage or 30V below the positive supply, whichever is less.

Note 2: The maximum junction temperature is 150°C . For operating at elevated temperatures, devices in the flat package, the derating is based on a thermal resistance of $185^\circ\text{C}/\text{W}$ when mounted on a $1/16$ -inch-thick epoxy glass board with 0.03-inch-wide, 2 ounce copper conductor. The thermal resistance of the dual-in-line package is $100^\circ\text{C}/\text{W}$, junction to ambient.

Note 3: These specifications apply for $V_S = \pm 15V$ and $-55^\circ\text{C} \leq T_A \leq 125^\circ\text{C}$ for the LH2111, and $0^\circ\text{C} \leq T_A \leq 70^\circ\text{C}$ for the LH2311, unless otherwise stated. The offset voltage, offset current and bias current specifications apply for any supply voltage from a single 5V supply up to $\pm 15V$ supplies. For the LH2311, $V_{IN} = \pm 10\text{ mV}$.

Note 4: The offset voltages and offset currents given are the maximum values required to drive the output within a volt of either supply with a 1 mA load. Thus, these parameters define an error band and take into account the worst case effects of voltage gain and input impedance.

Note 5: The response time specified is for a 100 mV input step with 5 mV overdrive.

Note 6: RETS2111X for the LH2111D and LH2111F military specifications.

Auxiliary Circuits

Offset Balancing

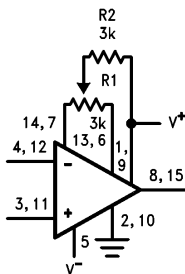

TL/K/10116-2

Strobing

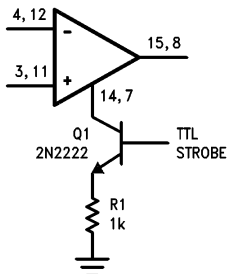

TL/K/10116-3

Increasing Input Stage Current*

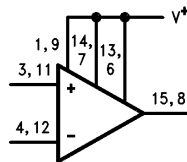

TL/K/10116-4

*Increases typical common mode slew from 7.0 V/ μ s to 18 V/ μ s

Driving Ground-Referred Load

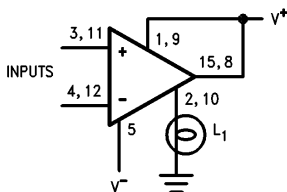

TL/K/10116-5

Using Clamp Diodes to Improve Responses

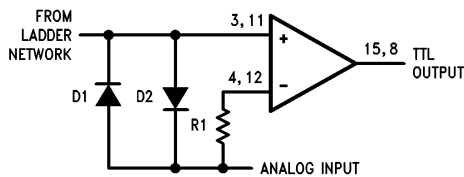

TL/K/10116-6

Comparator and Solenoid Driver

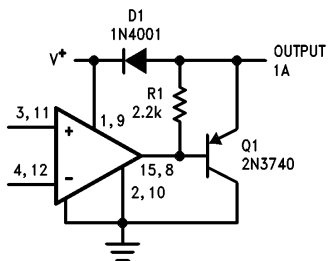

TL/K/10116-7

Strobing off Both Input* and Output Stages

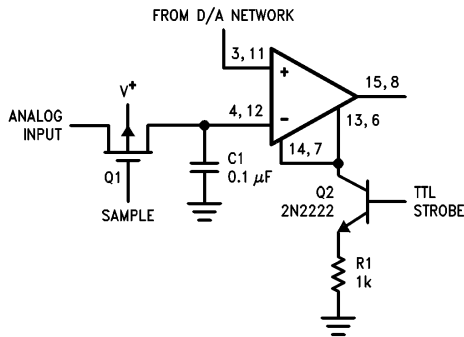

TL/K/10116-8

*Typical input current is 50 pA with inputs strobed off

TTL Interface with High Level Logic

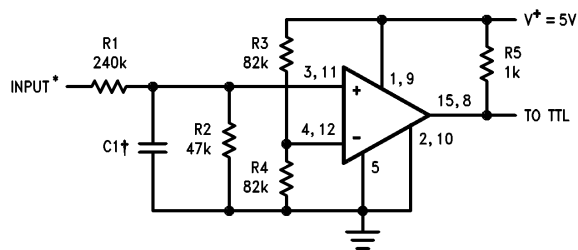

*Values shown are for a 0V to 30V logic swing and a 15V threshold.

†May be added to control speed and reduce susceptibility to noise spikes.

TL/K/10116-9

Physical Dimensions inches (millimeters)

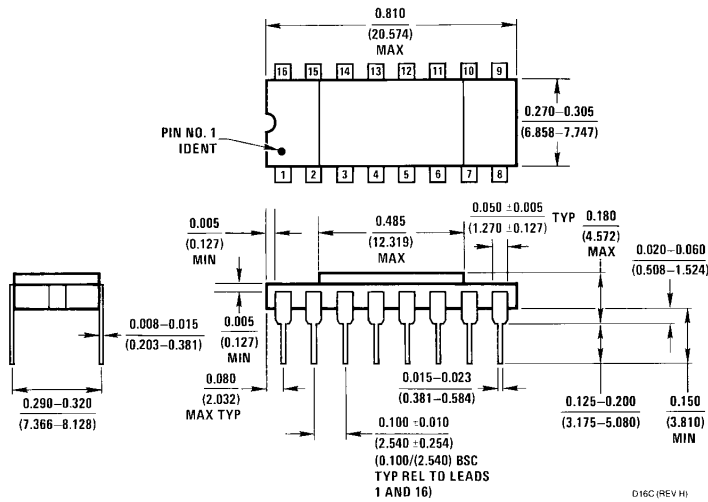

16-Lead Hermetic Dual-In-Line Package (D)
Order Number LH2111D, LH2111D/883 or LH2311D
NS Package Number D16C

D16C (REV H)

LIFE SUPPORT POLICY

NATIONAL'S PRODUCTS ARE NOT AUTHORIZED FOR USE AS CRITICAL COMPONENTS IN LIFE SUPPORT DEVICES OR SYSTEMS WITHOUT THE EXPRESS WRITTEN APPROVAL OF THE PRESIDENT OF NATIONAL SEMICONDUCTOR CORPORATION. As used herein:

1. Life support devices or systems are devices or systems which, (a) are intended for surgical implant into the body, or (b) support or sustain life, and whose failure to perform, when properly used in accordance with instructions for use provided in the labeling, can be reasonably expected to result in a significant injury to the user.
2. A critical component is any component of a life support device or system whose failure to perform can be reasonably expected to cause the failure of the life support device or system, or to affect its safety or effectiveness.



National Semiconductor Corporation
 1111 West Bardin Road
 Arlington, TX 76017
 Tel: 1(800) 272-9959
 Fax: 1(800) 737-7018

National Semiconductor Europe
 Fax: (+49) 0-180-530 85 86
 Email: onjwge@tevm2.nsc.com
 Deutsch Tel: (+49) 0-180-530 85 85
 English Tel: (+49) 0-180-532 78 32
 Français Tel: (+49) 0-180-532 93 58
 Italiano Tel: (+49) 0-180-534 16 80

National Semiconductor Hong Kong Ltd.
 19th Floor, Straight Block,
 Ocean Centre, 5 Canton Rd.
 Tsimshatsui, Kowloon
 Hong Kong
 Tel: (852) 2737-1600
 Fax: (852) 2736-9960

National Semiconductor Japan Ltd.
 Tel: 81-043-299-2309
 Fax: 81-043-299-2408

National does not assume any responsibility for use of any circuitry described, no circuit patent licenses are implied and National reserves the right at any time without notice to change said circuitry and specifications.